

JOSEFOV KOLEM

Revitalizácia pevnostného mesta

Akoby zastal čas. Zanedbaný, zabudnutý, chátrajúci. Pevnostné mesto Josefov napriek svojej historickej a architektonickej hodnote ostáva nepoznané. Cieľom diplomovej práce je pomocou drobných zásahov poukázať na prednosti a prirodzenú atmosféru pevnosti.

Skúmať, hľdať, strátiť sa a nájsť. Návštevník nasleduje pešie, či cyklistické okruhy, prechádza historickými tunelmi v kurtínách a vychutnáva si pevnosť inak - v novom rekreačnom areáli, saune, alebo v kapslovom hosteli v kasárniach bastionu XI.

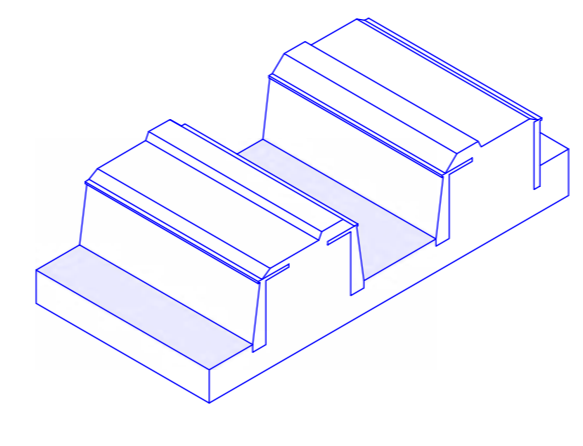
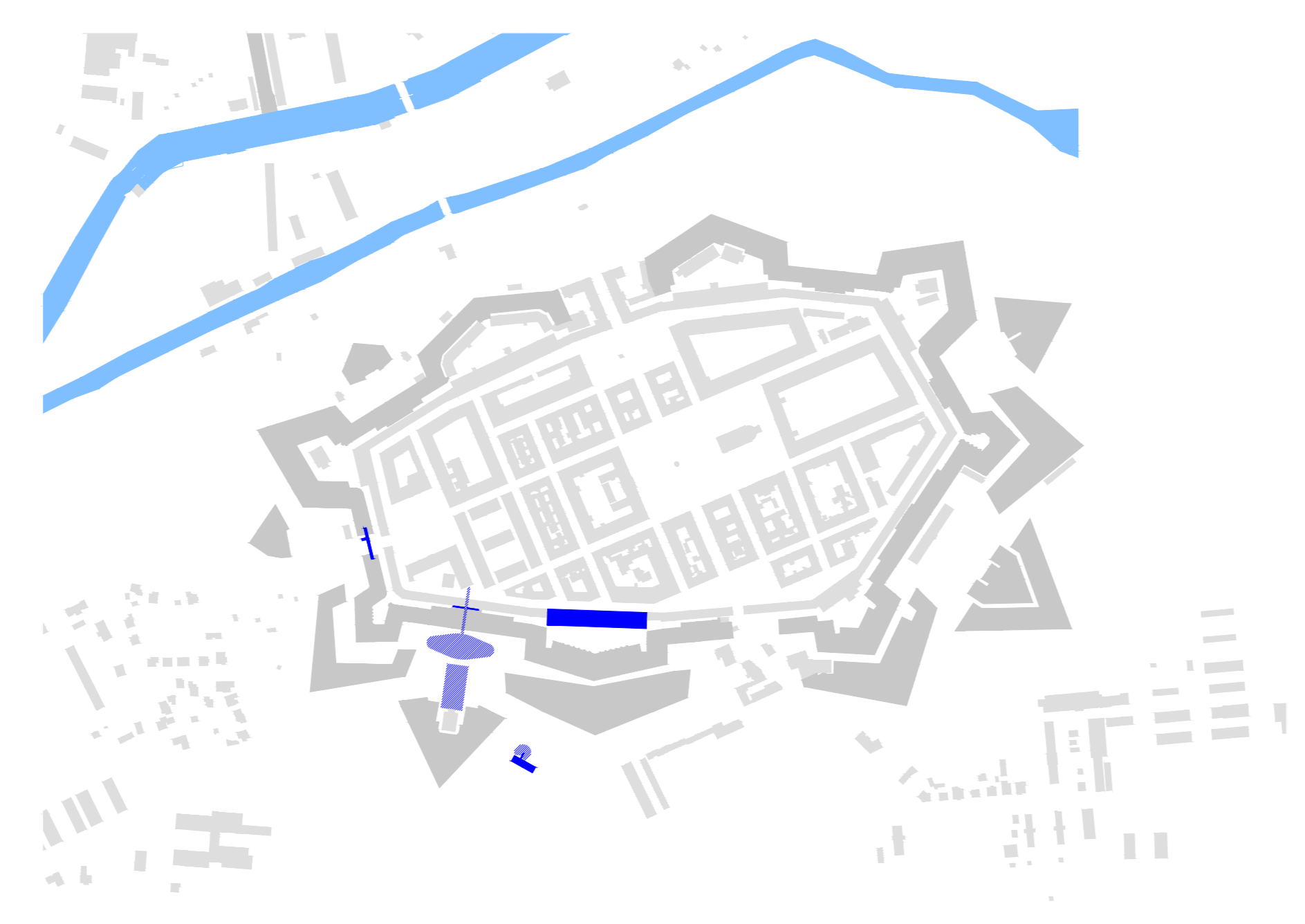

Sprístupenie hradiab a okolia
 vytvorenie pešieho okruhu medzi hradiabmi
 vytvorenie cyklookruhu za hradiabmi, napojeného na Labskú cyklotrasu.

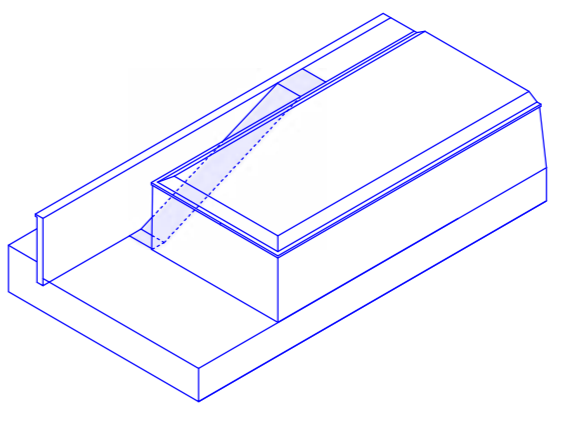

Obnovenie rámp
 sprístupnenie hradobného valu obnovou peších rámp v bastionoch.

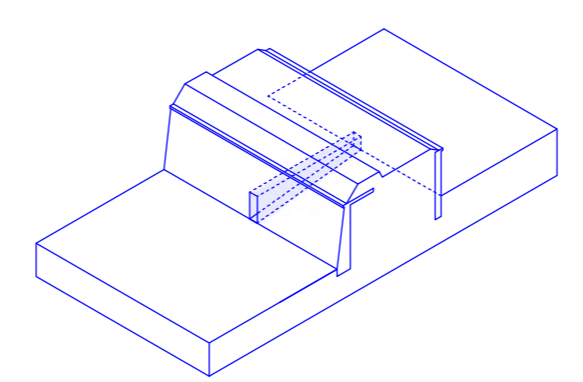

Prepojenie s mestom
 aktivácia hluchých miest a ich prepojenie s mestom pomocou tunelov v kurtínách.

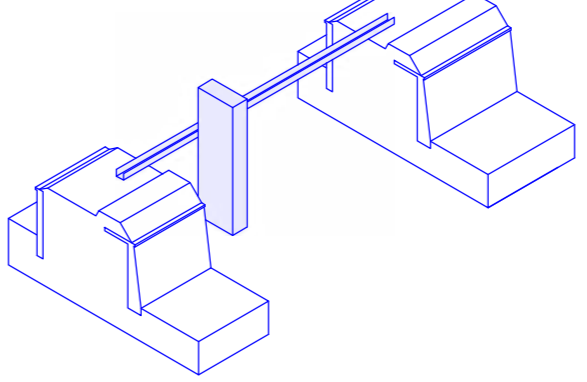

Hradobný okruh
 Pešia trasa priamo na hradobnom vale. Doplnenie preusulých častí v meste pôvodných brán.

